

Worm

geared motors

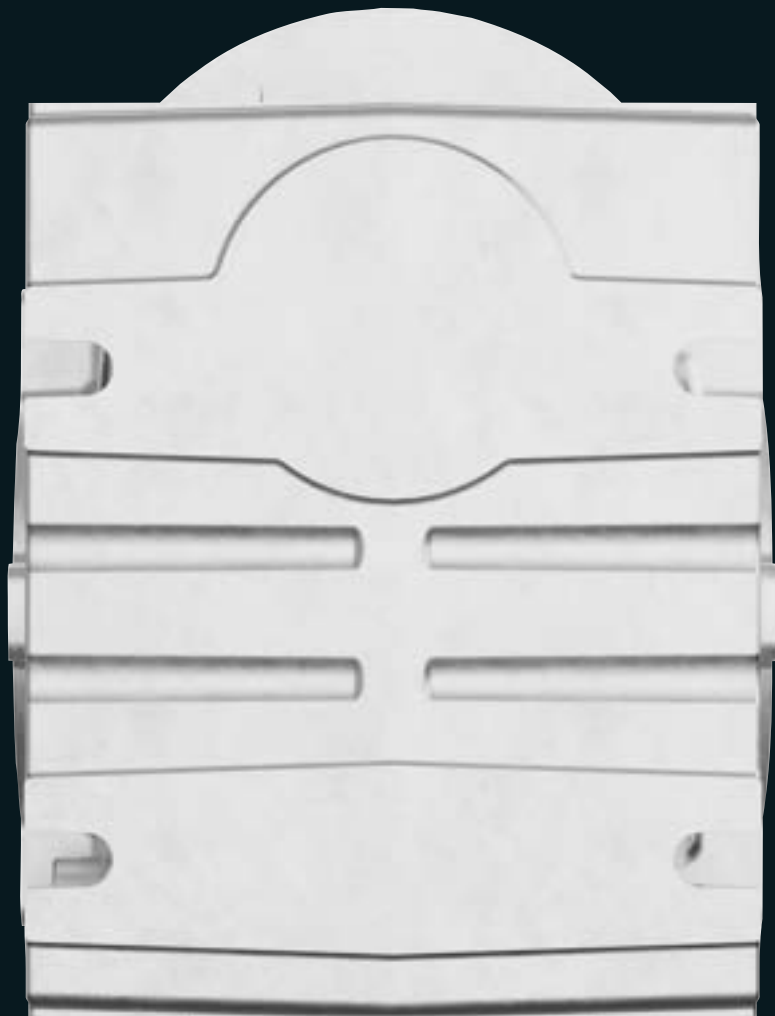



7 Worm geared motors

7/2 Orientation

1

7/3 Geared motors up to 0.37 kW

7/3 Selection and ordering data

2

7/5 Transmission ratios and torques

7/5 Selection and ordering data

3

7/7 General technical specifications

7/7 Permissible radial force

4

7/8 Dimensional drawings

7/8 Overview

5

7/9 Worm geared motors S..09

7/13 Worm geared motors S..19

7/17 Worm geared motors S..29

7/21 Protective cover for hollow shaft

6

7

8

9

10

11

12

13

14

Worm geared motors

Worm geared motors 1-stage

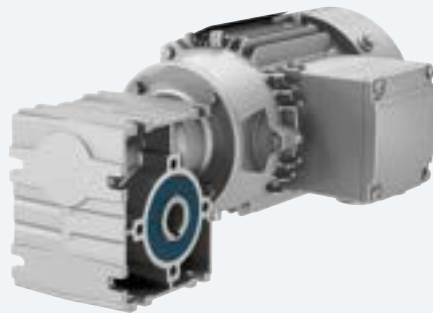

Fig. 7-1 Worm geared motor S

Designs	Mounting	Frame sizes	Maximum output torque T_{2N} Nm	Transmission ratio i –	Maximum motor power P_1 kW	Supported motors
<ul style="list-style-type: none"> _ Foot-mounted design _ Flange-mounted design _ Design with integrated housing flange _ Shaft-mounted design 	<ul style="list-style-type: none"> _ Hollow shaft design with feather key _ Hollow shaft design with plug-in shaft SE _ Solid shaft design with feather key (at one end or both ends) 	S09 ... S29	33 ... 116	5.0 ... 100	0.55	<ul style="list-style-type: none"> _ Induction motors with B14 flange

Selection and ordering data

P_N	n_2	T_2	i	F_{R2}	f_B	m	Article No.	Additional identification code -Z with order code	
kW	rpm	Nm	-	N	-	kg	(Article No. supplement, see below)	No. of poles	
0.09	S.29-LEI63MEB6								
	8.9	44	100	3530	1.6	9	2KJ3732- ■ BD21- ■ ■ A1 -Z	P01	
	11	39	80	3550	2.2	9	2KJ3732- ■ BD21- ■ ■ B1 -Z	P01	
	S.19-LEI63MEB6								
	11	38	80	3550	0.94	6	2KJ3731- ■ BD21- ■ ■ B1 -Z	P01	
	15	32	60	3580	1.5	6	2KJ3731- ■ BD21- ■ ■ C1 -Z	P01	
	S.09-LEI63MEB6								
	15	29	60	1700	0.84	6	2KJ3730- ■ BD21- ■ ■ C1 -Z	P01	
	18	26	50	1720	1.1	6	2KJ3730- ■ BD21- ■ ■ D1 -Z	P01	
	22	22	40	1730	1.3	6	2KJ3730- ■ BD21- ■ ■ E1 -Z	P01	
0.12	S.29-LEI63ZMH4P								
	14	39	100	3550	1.8	10	2KJ3732- ■ BD23- ■ ■ A1 -Z	-	
	17	35	80	3560	2.3	10	2KJ3732- ■ BD23- ■ ■ B1 -Z	-	
	23	29	60	3590	2.8	10	2KJ3732- ■ BD23- ■ ■ C1 -Z	-	
	28	26	50	3600	3	10	2KJ3732- ■ BD23- ■ ■ D1 -Z	-	
	35	22	40	3620	3.5	10	2KJ3732- ■ BD23- ■ ■ E1 -Z	-	
	46	18	30	3640	4.2	10	2KJ3732- ■ BD23- ■ ■ F1 -Z	-	
	56	16	25	3640	4.8	10	2KJ3732- ■ BD23- ■ ■ G1 -Z	-	
	S.19-LEI63ZMH4P								
	17	34	80	3570	1	8	2KJ3731- ■ BD23- ■ ■ B1 -Z	-	
	23	29	60	3590	1.5	8	2KJ3731- ■ BD23- ■ ■ C1 -Z	-	
	28	26	50	3600	1.7	8	2KJ3731- ■ BD23- ■ ■ D1 -Z	-	
	35	22	40	3620	2	8	2KJ3731- ■ BD23- ■ ■ E1 -Z	-	
	46	18	30	3630	2.4	8	2KJ3731- ■ BD23- ■ ■ F1 -Z	-	
	56	16	25	3640	2.5	8	2KJ3731- ■ BD23- ■ ■ G1 -Z	-	
	70	13	20	3650	3.3	8	2KJ3731- ■ BD23- ■ ■ H1 -Z	-	
	93	10	15	3670	4.2	8	2KJ3731- ■ BD23- ■ ■ J1 -Z	-	
	S.09-LEI63ZMH4P								
	23	26	60	1720	0.91	7	2KJ3730- ■ BD23- ■ ■ C1 -Z	-	
	28	23	50	1730	1.1	7	2KJ3730- ■ BD23- ■ ■ D1 -Z	-	
	35	20	40	1740	1.4	7	2KJ3730- ■ BD23- ■ ■ E1 -Z	-	
	46	16	30	1760	1.7	7	2KJ3730- ■ BD23- ■ ■ F1 -Z	-	
	56	14	25	1760	1.9	7	2KJ3730- ■ BD23- ■ ■ G1 -Z	-	
	70	12	20	1770	2.2	7	2KJ3730- ■ BD23- ■ ■ H1 -Z	-	
	93	9.8	15	1780	2.7	7	2KJ3730- ■ BD23- ■ ■ J1 -Z	-	
	139	7	10	1790	3.9	7	2KJ3730- ■ BD23- ■ ■ K1 -Z	-	
	0.18	S.29-LEI71ZMK6P							
		11	80	80	3380	1.1	10	2KJ3732- ■ CC23- ■ ■ B1 -Z	P01
		S.29-LEI63ZMK4P							
		14	59	100	3460	1.2	10	2KJ3732- ■ BE23- ■ ■ A1 -Z	-
17		52	80	3490	1.5	10	2KJ3732- ■ BE23- ■ ■ B1 -Z	-	
23		44	60	3530	1.8	10	2KJ3732- ■ BE23- ■ ■ C1 -Z	-	
28		39	50	3550	2	10	2KJ3732- ■ BE23- ■ ■ D1 -Z	-	
35		33	40	3570	2.3	10	2KJ3732- ■ BE23- ■ ■ E1 -Z	-	
46		27	30	3600	2.8	10	2KJ3732- ■ BE23- ■ ■ F1 -Z	-	
55		23	25	3610	3.2	10	2KJ3732- ■ BE23- ■ ■ G1 -Z	-	
69		20	20	3630	3.8	10	2KJ3732- ■ BE23- ■ ■ H1 -Z	-	
92		16	15	3640	4.8	10	2KJ3732- ■ BE23- ■ ■ J1 -Z	-	
S.19-LEI63ZMK4P									
23		43	60	3530	1	8	2KJ3731- ■ BE23- ■ ■ C1 -Z	-	
28		38	50	3550	1.2	8	2KJ3731- ■ BE23- ■ ■ D1 -Z	-	
35		33	40	3570	1.3	8	2KJ3731- ■ BE23- ■ ■ E1 -Z	-	
46		27	30	3600	1.6	8	2KJ3731- ■ BE23- ■ ■ F1 -Z	-	
55		23	25	3610	1.7	8	2KJ3731- ■ BE23- ■ ■ G1 -Z	-	
69		20	20	3630	2.2	8	2KJ3731- ■ BE23- ■ ■ H1 -Z	-	
92		16	15	3640	2.8	8	2KJ3731- ■ BE23- ■ ■ J1 -Z	-	
138		11	10	3660	3.9	8	2KJ3731- ■ BE23- ■ ■ K1 -Z	-	
S.09-LEI63ZMK4P									
35		30	40	1700	0.93	7	2KJ3730- ■ BE23- ■ ■ E1 -Z	-	
46		25	30	1720	1.1	7	2KJ3730- ■ BE23- ■ ■ F1 -Z	-	
55		22	25	1730	1.3	7	2KJ3730- ■ BE23- ■ ■ G1 -Z	-	
69		19	20	1740	1.5	7	2KJ3730- ■ BE23- ■ ■ H1 -Z	-	

Article No. supplement

Shaft design	1 or 9	see page 10/51
Frequency and voltage	2 or 9	see page 11/2
Gearbox mounting type	A, F, H or D	see page 10/42

Geared motors up to 0.37 kW

Worm geared motors

Selection and ordering data

P_N	n_2	T_2	i	F_{R2}	f_B	m	Article No.	Additional identification code -Z with order code	
kW	rpm	Nm	-	N	-	kg	(Article No. supplement, see below)	No. of poles	
0.18	S.09-LEI63ZMK4P								
	92	15	15	1760	1.8	7	2KJ3730- BE23- J1	-Z	-
	138	10	10	1780	2.6	7	2KJ3730- BE23- K1	-Z	-
	198	7.7	7	1790	3.6	7	2KJ3730- BE23- L1	-Z	-
	277	5.6	5	1800	4.6	7	2KJ3730- BE23- M1	-Z	-
0.25	S.29-LEI71ZMK4P								
	17	72	80	3410	1.1	10	2KJ3732- CC23- B1	-Z	-
	23	60	60	3460	1.3	10	2KJ3732- CC23- C1	-Z	-
	28	54	50	3480	1.5	10	2KJ3732- CC23- D1	-Z	-
	35	46	40	3520	1.7	10	2KJ3732- CC23- E1	-Z	-
	46	37	30	3560	2	10	2KJ3732- CC23- F1	-Z	-
	56	32	25	3580	2.3	10	2KJ3732- CC23- G1	-Z	-
	70	27	20	3600	2.7	10	2KJ3732- CC23- H1	-Z	-
	93	22	15	3620	3.5	10	2KJ3732- CC23- J1	-Z	-
	140	15	10	3650	5	10	2KJ3732- CC23- K1	-Z	-
	S.19-LEI71ZMK4P								
	28	53	50	3490	0.84	8	2KJ3731- CC23- D1	-Z	-
	35	46	40	3520	0.96	8	2KJ3731- CC23- E1	-Z	-
	46	37	30	3550	1.2	8	2KJ3731- CC23- F1	-Z	-
	56	32	25	3580	1.2	8	2KJ3731- CC23- G1	-Z	-
	70	27	20	3600	1.6	8	2KJ3731- CC23- H1	-Z	-
	93	21	15	3620	2	8	2KJ3731- CC23- J1	-Z	-
	140	15	10	3650	2.8	8	2KJ3731- CC23- K1	-Z	-
	199	11	7	3660	3.7	8	2KJ3731- CC23- L1	-Z	-
	279	7.9	5	3680	4.9	8	2KJ3731- CC23- M1	-Z	-
0.37	S.29-LEI71YMS4P								
	23	90	60	3330	0.89	12	2KJ3732- CE23- C1	-Z	-
	28	80	50	3380	0.98	12	2KJ3732- CE23- D1	-Z	-
	34	69	40	3420	1.1	12	2KJ3732- CE23- E1	-Z	-
	46	56	30	3480	1.4	12	2KJ3732- CE23- F1	-Z	-
	55	48	25	3510	1.5	12	2KJ3732- CE23- G1	-Z	-
	69	41	20	3540	1.8	12	2KJ3732- CE23- H1	-Z	-
	92	32	15	3580	2.3	12	2KJ3732- CE23- J1	-Z	-
	138	22	10	3620	3.3	12	2KJ3732- CE23- K1	-Z	-
	197	16	7	3640	4.5	12	2KJ3732- CE23- L1	-Z	-
	S.19-LEI71YMS4P								
	55	48	25	3510	0.81	10	2KJ3731- CE23- G1	-Z	-
	69	41	20	3540	1.1	10	2KJ3731- CE23- H1	-Z	-
	92	32	15	3580	1.3	10	2KJ3731- CE23- J1	-Z	-
	138	22	10	3620	1.9	10	2KJ3731- CE23- K1	-Z	-
197	16	7	3640	2.5	10	2KJ3731- CE23- L1	-Z	-	
276	12	5	3660	3.3	10	2KJ3731- CE23- M1	-Z	-	

Article No. supplement

Shaft design	1 or 9	see page 10/51
Frequency and voltage	2 or 9	see page 11/2
Gearbox mounting type	A, F, H or D	see page 10/42

Worm geared motors

Selection and ordering data

i	Lead angle of the worm γm	n _{mot} = 2 800 rpm				n _{mot} = 1 400 rpm				Motor frame size		Article No. (Article No. supplement, see below)
		n ₂ rpm	T _{2N} Nm	P _{mot} kW	η %	n ₂ rpm	T _{2N} Nm	P _{mot} kW	η %	63	71	
S.09												
80	2.1	35.0	18	0.14	48	17.5	19	0.07	47	✓		2KJ3730 - ■■■■■■ - ■■ B1
60	2.7	46.7	22	0.20	55	23.3	24	0.11	52	✓		2KJ3730 - ■■■■■■ - ■■ C1
50	3.2	56.0	21	0.21	58	28.0	27	0.14	56	✓		2KJ3730 - ■■■■■■ - ■■ D1
40	3.8	70.0	21	0.24	63	35.0	28	0.17	61	✓		2KJ3730 - ■■■■■■ - ■■ E1
30	4.6	93.3	20	0.29	68	46.7	28	0.20	67	✓		2KJ3730 - ■■■■■■ - ■■ F1
25	5.2	112.0	20	0.33	72	56.0	27	0.23	70	✓		2KJ3730 - ■■■■■■ - ■■ G1
20	7.4	140.0	21	0.40	77	70.0	27	0.26	75	✓		2KJ3730 - ■■■■■■ - ■■ H1
15	9.2	186.7	20	0.48	81	93.3	27	0.33	80	✓		2KJ3730 - ■■■■■■ - ■■ J1
10	14.0	280.0	20	0.68	86	140.0	27	0.47	85	✓		2KJ3730 - ■■■■■■ - ■■ K1
7	19.0	400.0	19	0.89	89	200.0	26	0.62	88	✓		2KJ3730 - ■■■■■■ - ■■ L1
5	25.0	560.0	19	1.22	91	280.0	25	0.81	91	✓		2KJ3730 - ■■■■■■ - ■■ M1
S.19												
80	3.5	35.0	33	0.22	55	17.5	35	0.12	54	✓		2KJ3731 - ■■■■■■ - ■■ B1
60	3.5	46.7	33	0.26	61	23.3	44	0.18	59	✓		2KJ3731 - ■■■■■■ - ■■ C1
50	4.0	56.0	33	0.30	64	28.0	44	0.20	63	✓	✓	2KJ3731 - ■■■■■■ - ■■ D1
40	4.5	70.0	31	0.33	68	35.0	43	0.24	67	✓	✓	2KJ3731 - ■■■■■■ - ■■ E1
30	5.5	93.3	31	0.42	73	46.7	41	0.28	72	✓	✓	2KJ3731 - ■■■■■■ - ■■ F1
25	6.5	112.0	31	0.48	76	56.0	41	0.32	75	✓	✓	2KJ3731 - ■■■■■■ - ■■ G1
20	9.5	140.0	31	0.56	81	70.0	41	0.38	80	✓	✓	2KJ3731 - ■■■■■■ - ■■ H1
15	11.0	186.7	30	0.70	84	93.3	41	0.48	84	✓	✓	2KJ3731 - ■■■■■■ - ■■ J1
10	17.0	280.0	30	1.00	88	140.0	40	0.67	88	✓	✓	2KJ3731 - ■■■■■■ - ■■ K1
7	17.0	400.0	29	1.33	91	200.0	39	0.91	90	✓	✓	2KJ3731 - ■■■■■■ - ■■ L1
5	23.0	560.0	28	1.78	92	280.0	37	1.18	92	✓	✓	2KJ3731 - ■■■■■■ - ■■ M1
S.29												
100	2.0	28.0	57	0.33	50	14.0	72	0.22	49	✓		2KJ3732 - ■■■■■■ - ■■ A1
80	2.5	35.0	57	0.39	54	17.5	80	0.27	54	✓	✓	2KJ3732 - ■■■■■■ - ■■ B1
60	3.0	46.7	57	0.46	60	23.3	78	0.32	59	✓	✓	2KJ3732 - ■■■■■■ - ■■ C1
50	3.5	56.0	55	0.50	64	28.0	75	0.35	63	✓	✓	2KJ3732 - ■■■■■■ - ■■ D1
40	4.5	70.0	55	0.59	68	35.0	74	0.40	68	✓	✓	2KJ3732 - ■■■■■■ - ■■ E1
30	5.0	93.3	53	0.71	73	46.7	73	0.49	73	✓	✓	2KJ3732 - ■■■■■■ - ■■ F1
25	6.0	112.0	53	0.82	76	56.0	73	0.56	76	✓	✓	2KJ3732 - ■■■■■■ - ■■ G1
20	8.5	140.0	53	0.96	81	70.0	73	0.67	80	✓	✓	2KJ3732 - ■■■■■■ - ■■ H1
15	10.0	186.7	53	1.23	84	93.3	72	0.84	84	✓	✓	2KJ3732 - ■■■■■■ - ■■ J1
10	15.0	280.0	53	1.77	88	140.0	72	1.20	88	✓	✓	2KJ3732 - ■■■■■■ - ■■ K1
7	15.0	400.0	53	2.44	91	200.0	71	1.63	91	✓	✓	2KJ3732 - ■■■■■■ - ■■ L1
5	21.0	560.0	51	3.22	93	280.0	69	2.18	93	✓	✓	2KJ3732 - ■■■■■■ - ■■ M1

Article No. supplement

Shaft design	1 or 9	see page 10/51
Motor frame size, motor type, efficiency class		see chapter 9
Frequency and voltage	2 or 9	see page 11/2
Gearbox mounting type	A, F, H or D	see page 10/42

Worm geared motors

Selection and ordering data

i	Lead angle of the worm γ _m	n _{mot} = 900 rpm				n _{mot} = 500 rpm				Motor frame size		Article No. (Article No. supplement, see below)
		n ₂ rpm	T _{2N} Nm	P _{mot} kW	η %	n ₂ rpm	T _{2N} Nm	P _{mot} kW	η %	63	71	
S.09												
80	2.1	11.3	19	0.05	44	6.3	20	0.03	40	✓		2KJ3730 - ■■■■■■ - ■■ B1
60	2.7	15.0	24	0.08	50	8.3	24	0.05	45	✓		2KJ3730 - ■■■■■■ - ■■ C1
50	3.2	18.0	27	0.10	53	10.0	28	0.06	49	✓		2KJ3730 - ■■■■■■ - ■■ D1
40	3.8	22.5	31	0.13	58	12.5	31	0.08	54	✓		2KJ3730 - ■■■■■■ - ■■ E1
30	4.6	30.0	32	0.16	64	16.7	33	0.10	60	✓		2KJ3730 - ■■■■■■ - ■■ F1
25	5.2	36.0	32	0.18	68	20.0	32	0.10	64	✓		2KJ3730 - ■■■■■■ - ■■ G1
20	7.4	45.0	31	0.20	73	25.0	31	0.12	70	✓		2KJ3730 - ■■■■■■ - ■■ H1
15	9.2	60.0	33	0.27	78	33.3	33	0.15	75	✓		2KJ3730 - ■■■■■■ - ■■ J1
10	14.0	90.0	32	0.36	84	50.0	33	0.21	81	✓		2KJ3730 - ■■■■■■ - ■■ K1
7	19.0	128.6	31	0.48	87	71.4	33	0.29	85	✓		2KJ3730 - ■■■■■■ - ■■ L1
5	25.0	180.0	30	0.63	90	100.0	33	0.39	88	✓		2KJ3730 - ■■■■■■ - ■■ M1
S.19												
80	3.5	11.3	35	0.08	51	6.3	36	0.05	47	✓		2KJ3731 - ■■■■■■ - ■■ B1
60	3.5	15.0	49	0.14	57	8.3	51	0.09	52	✓		2KJ3731 - ■■■■■■ - ■■ C1
50	4.0	18.0	51	0.16	61	10.0	59	0.11	56	✓	✓	2KJ3731 - ■■■■■■ - ■■ D1
40	4.5	22.5	51	0.18	65	12.5	64	0.14	61	✓	✓	2KJ3731 - ■■■■■■ - ■■ E1
30	5.5	30.0	50	0.22	70	16.7	63	0.17	66	✓	✓	2KJ3731 - ■■■■■■ - ■■ F1
25	6.5	36.0	49	0.25	74	20.0	62	0.19	70	✓	✓	2KJ3731 - ■■■■■■ - ■■ G1
20	9.5	45.0	50	0.30	78	25.0	62	0.22	75	✓	✓	2KJ3731 - ■■■■■■ - ■■ H1
15	11.0	60.0	50	0.38	82	33.3	62	0.27	79	✓	✓	2KJ3731 - ■■■■■■ - ■■ J1
10	17.0	90.0	49	0.53	87	50.0	61	0.38	85	✓	✓	2KJ3731 - ■■■■■■ - ■■ K1
7	17.0	128.6	47	0.70	90	71.4	58	0.49	88	✓	✓	2KJ3731 - ■■■■■■ - ■■ L1
5	23.0	180.0	44	0.91	91	100.0	56	0.65	90	✓	✓	2KJ3731 - ■■■■■■ - ■■ M1
S.29												
100	2.0	9.0	72	0.14	47	5.0	72	0.09	43	✓		2KJ3732 - ■■■■■■ - ■■ A1
80	2.5	11.3	92	0.21	52	6.3	93	0.13	48	✓	✓	2KJ3732 - ■■■■■■ - ■■ B1
60	3.0	15.0	93	0.26	57	8.3	116	0.19	53	✓	✓	2KJ3732 - ■■■■■■ - ■■ C1
50	3.5	18.0	90	0.28	61	10.0	115	0.21	57	✓	✓	2KJ3732 - ■■■■■■ - ■■ D1
40	4.5	22.5	90	0.32	66	12.5	113	0.24	62	✓	✓	2KJ3732 - ■■■■■■ - ■■ E1
30	5.0	30.0	86	0.38	72	16.7	110	0.28	68	✓	✓	2KJ3732 - ■■■■■■ - ■■ F1
25	6.0	36.0	85	0.43	75	20.0	109	0.32	71	✓	✓	2KJ3732 - ■■■■■■ - ■■ G1
20	8.5	45.0	85	0.51	79	25.0	109	0.38	76	✓	✓	2KJ3732 - ■■■■■■ - ■■ H1
15	10.0	60.0	85	0.64	83	33.3	109	0.47	81	✓	✓	2KJ3732 - ■■■■■■ - ■■ J1
10	15.0	90.0	85	0.92	87	50.0	109	0.66	86	✓	✓	2KJ3732 - ■■■■■■ - ■■ K1
7	15.0	128.6	84	1.26	90	71.4	107	0.90	89	✓	✓	2KJ3732 - ■■■■■■ - ■■ L1
5	21.0	180.0	82	1.68	92	100.0	105	1.21	91	✓	✓	2KJ3732 - ■■■■■■ - ■■ M1

Article No. supplement

Shaft design	1 or 9	see page 10/51
Motor frame size, motor type, efficiency class		see chapter 9
Frequency and voltage	2 or 9	see page 11/2
Gearbox mounting type	A, F, H or D	see page 10/42

Permissible radial force F_{Rperm} **Radial force conversion for out-of-center force application point**

If the force is not applied at the center of the shaft extension, the permissible radial force must be calculated using the following formula.

The lower value of F_{xperm1} (bearing service life) and F_{xperm2} (strength) is the permissible radial force. The calculation is applicable without axial force.

Permissible radial force according to the bearing service life

$$F_{xperm1} = F_{R2} \cdot \frac{y}{(z+x)}$$

Permissible radial force according to the shaft strength

$$F_{xperm2} = \frac{a}{(b+x)}$$

Gearbox type	d mm	l mm	y mm	z mm	a kNmm	F_{Rperm} in N with $x = l/2$ for output speeds n_2 in rpm							
						≤ 16	≤ 25	≤ 40	≤ 63	≤ 100	≤ 160	≤ 250	≤ 400
S09	16	40	83.5	63.5	36	1800	1800	1800	1800	1800	1690	1400	1120
SF09			106.0	86.0		1800	1800	1800	1800	1620	1330	1100	880
S19	20	40	98.0	78.0	76	3800	3800	3800	3200	2650	2180	1780	1420
SF19			128.0	108.0		3200	3120	2920	2450	2030	1670	1360	1090
S29	20	40	120.5	100.5	72	3600	3600	3600	3600	3600	3290	2680	2120
SF29			153.5	133.5		3600	3600	3600	3600	3150	2580	2110	1660

Worm geared motors

Overview

Notes on the dimensional drawings are provided in chapter Introduction on page 1/23.

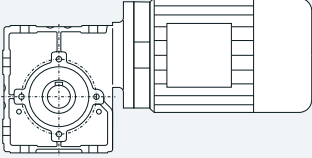
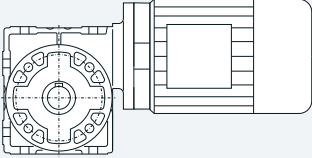
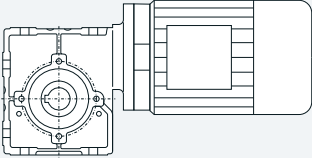
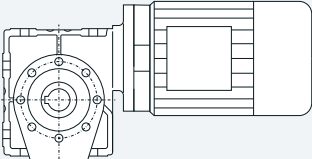
Design	Frame size	Dimensional drawing, see page
Worm geared motor S		
<i>Foot-mounted design</i>		
	S.09	7/9
	S.19	7/13
	S.29	7/17
<i>Flange-mounted design</i>		
	S.F09	7/10
	S.F19	7/14
	S.F29	7/18
<i>Housing flange design</i>		
	S.Z09	7/11
	S.Z19	7/15
	S.Z29	7/19
<i>Shaft-mounted design</i>		
	SAD09	7/12
	SAD19	7/16
	SAD29	7/20
Additional versions and options		
	Protective cover for hollow shafts	7/21

Worm geared motors

1-stage

Gearbox S.F09 in a flange-mounted design

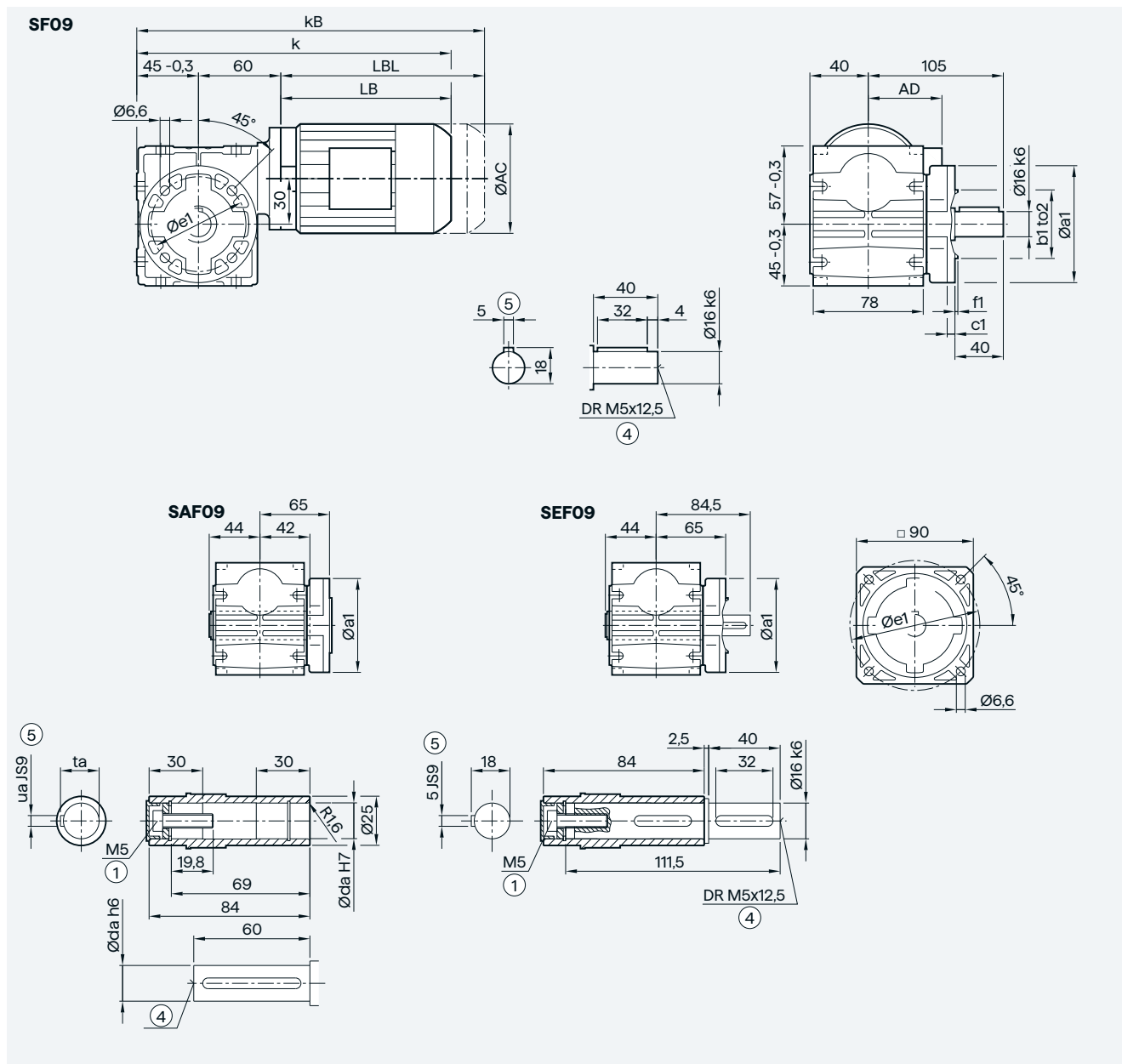

Hollow shaft	da		ua		ta		
	14		5		16.3		
	16		5		18.3		
Flange	a1	e1	b1	to2	c1	f1	
	80	65	50	j6	7	2.5	
	120	100	80	j6	7	3.0	
Motor	AC	AD ¹⁾	k	kB	LB	LBL	
	LEI63	117.8	101	284.5	335.5	179.5	230.5
	LEI63Z	117.8	101	310.5	361.5	205.5	256.5

① ISO 4014

② DIN 332

③ Feather key/keyway DIN 6885-1

¹⁾ AD depends on the motor options, for other dimensions, see page 9/53.

Gearbox S.Z09 in a housing flange design

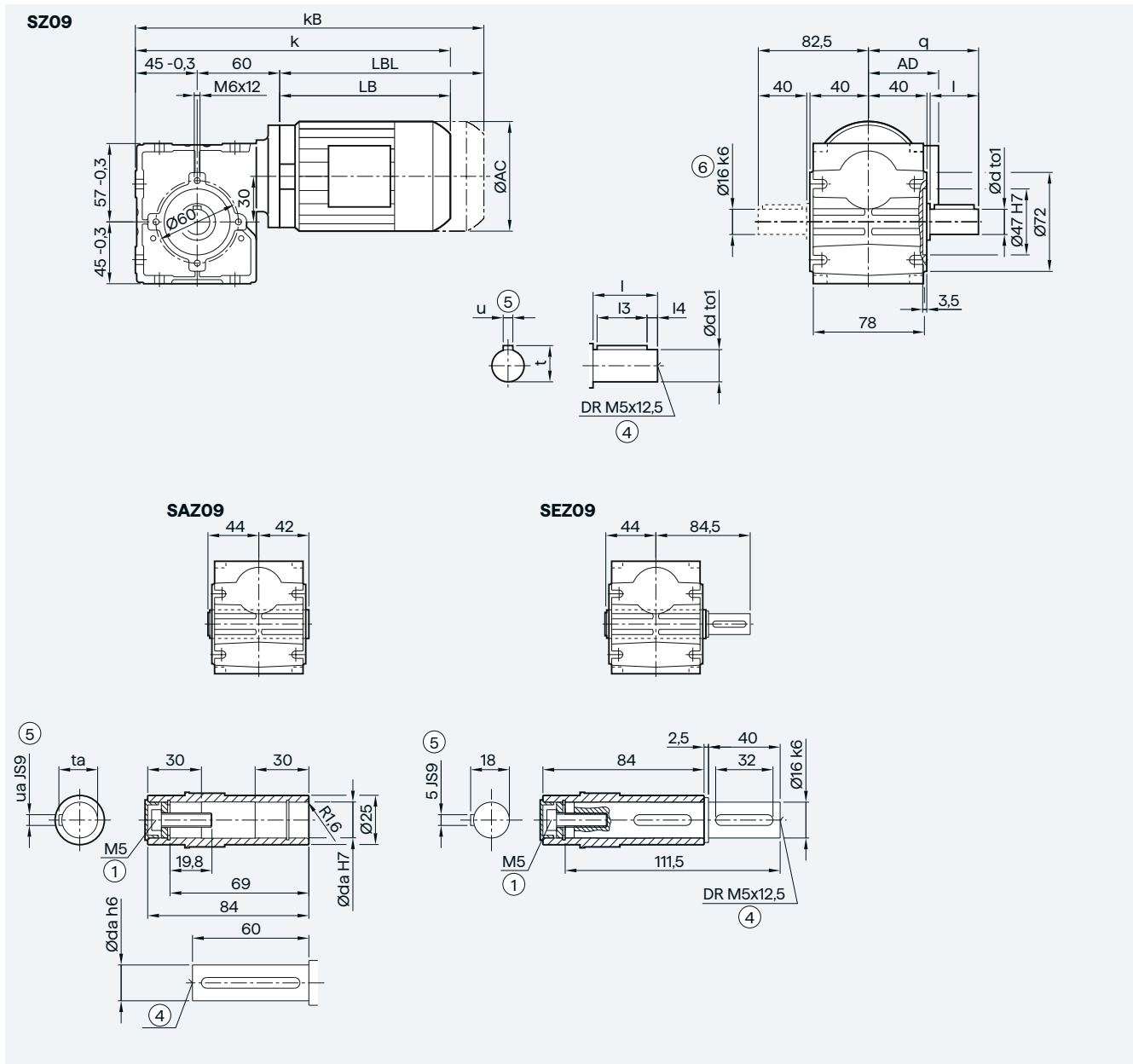

7

Solid shaft	d	to1	l	l3	l4	u	t	q	Hollow shaft	da	ua	ta
	14	k6	30	22	4	5	16	72.5		14	5	16.3
	16	k6	40	32	4	5	18	82.5		16	5	18.3
Motor	AC		AD ¹⁾		k		kB			LB		LBL
LEI63	117.8		101		284.5		335.5			179.5		230.5
LEI63Z	117.8		101		310.5		361.5			205.5		256.5

① ISO 4014

② DIN 332

③ Feather key/keyway DIN 6885-1

④ Solid shaft with 2nd shaft extension only d16

¹⁾ AD depends on the motor options, for other dimensions, see page 9/53.

Worm geared motors

1-stage

Gearbox SAD09 in a shaft-mounted design

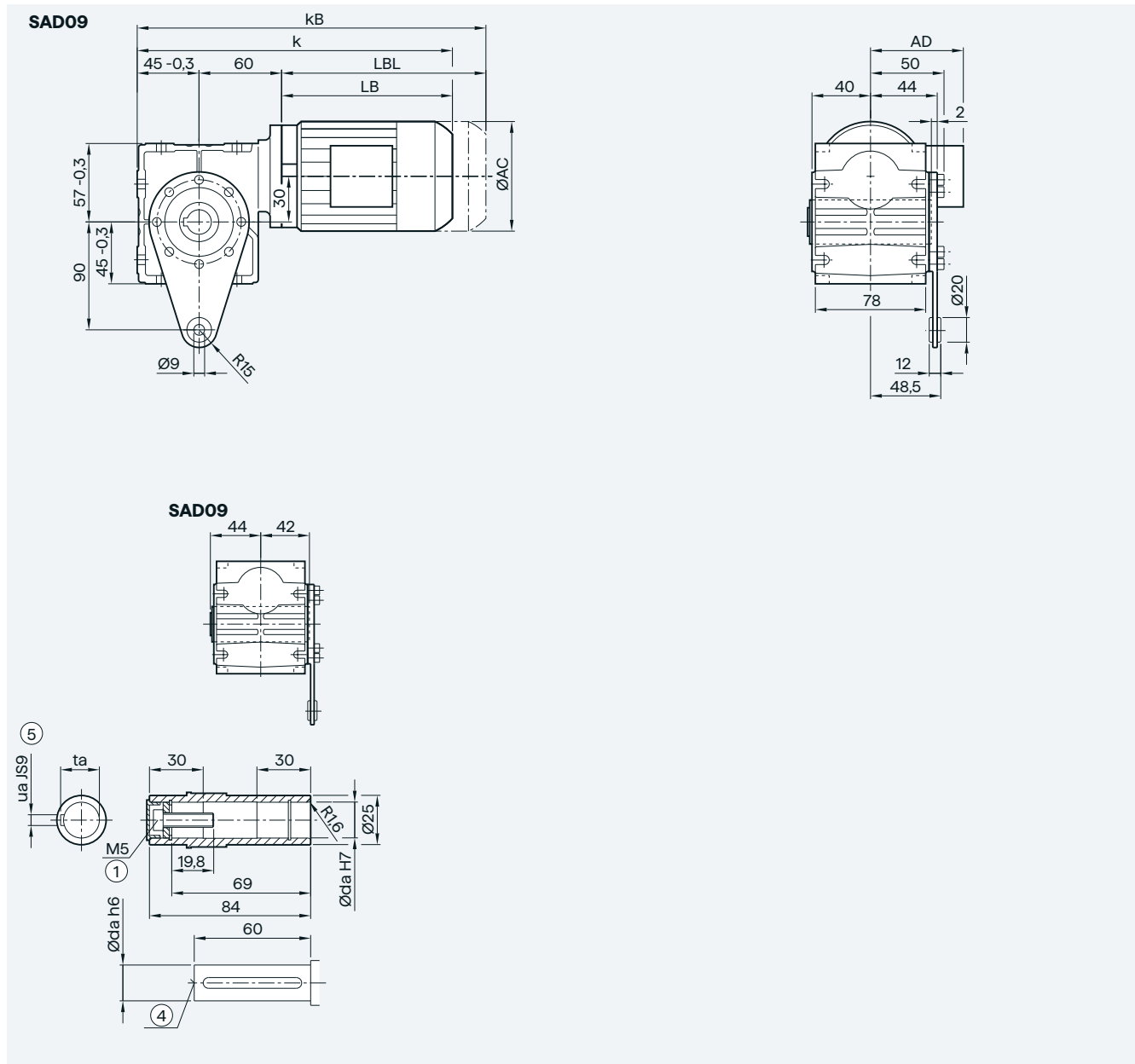

7

Hollow shaft	da	ua	ta			
	14	5	16.3			
	16	5	18.3			
Motor	AC	AD ¹⁾	k	kB	LB	LBL
LEI63	117.8	101	284.5	335.5	179.5	230.5
LEI63Z	117.8	101	310.5	361.5	205.5	256.5

① ISO 4014

② DIN 332

③ Feather key/keyway DIN 6885-1

¹⁾ AD depends on the motor options, for other dimensions, see page 9/53.

Worm geared motors

1-stage

Gearbox S.F19 in a flange-mounted design

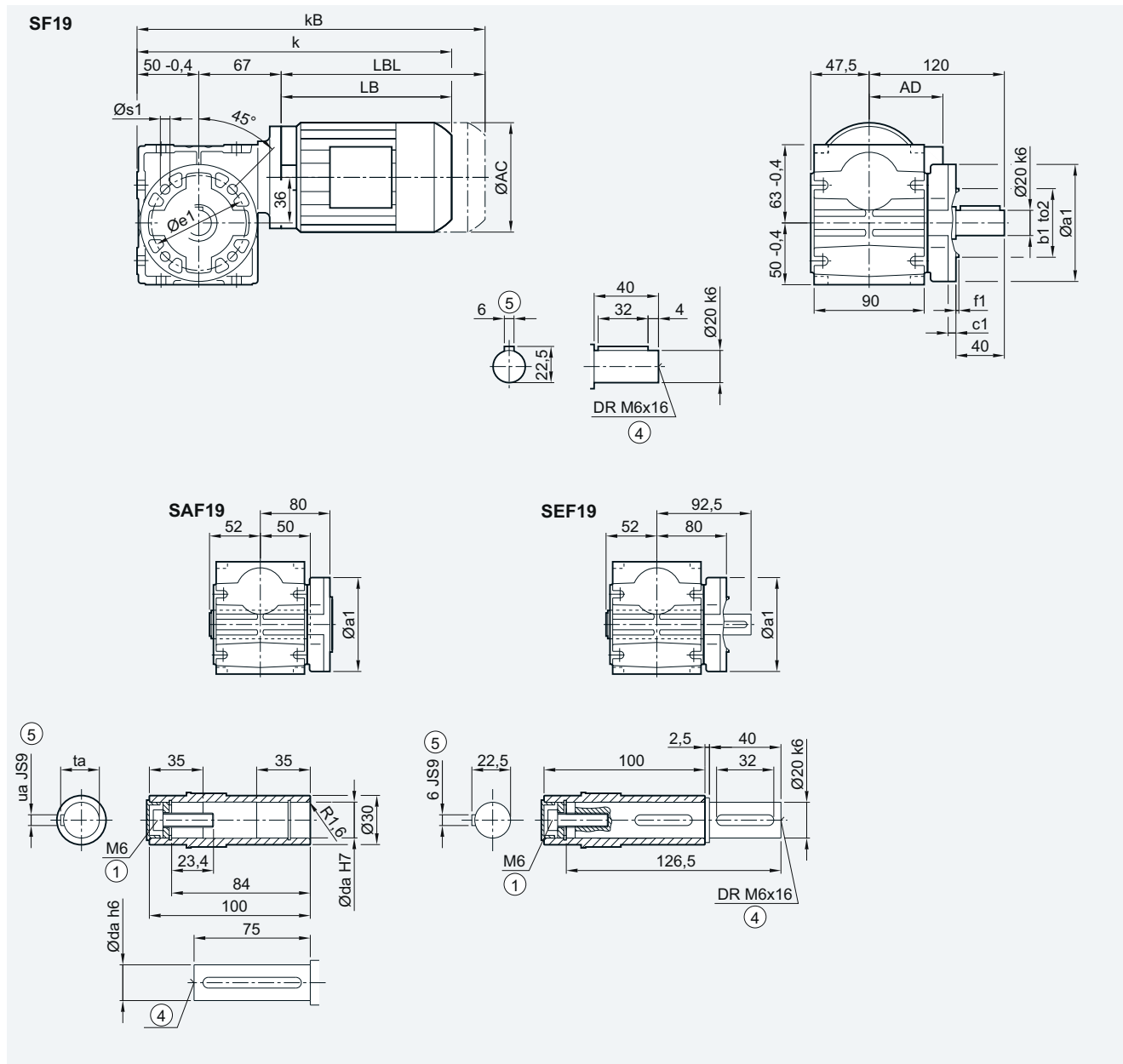

Hollow shaft	da		ua		ta		
	18		6		20.8		
	20		6		22.8		
Flange	a1	e1	b1	to2	c1	f1	s1
	110	87	60	H8	8	4.0	9
	120	100	80	j6	8	3.0	6.6
Motor	AC	AD ¹⁾	k	kB	LB	LBL	
LEI63	117.8	101	296.5	347.5	179.5	230.5	
LEI63Z	117.8	101	322.5	373.5	205.5	256.5	
LEI71	138.8	111	327.0	378.5	210	261.5	
LEI71Z	138.8	111	343.5	398.5	226.5	281.5	
LEI71Y	138.8	111	383.5	438.5	266.5	321.5	

① ISO 4014

② DIN 332

③ Feather key/keyway DIN 6885-1

¹⁾ AD depends on the motor options, for other dimensions, see page 9/53.

Gearbox S.Z19 in a housing flange design

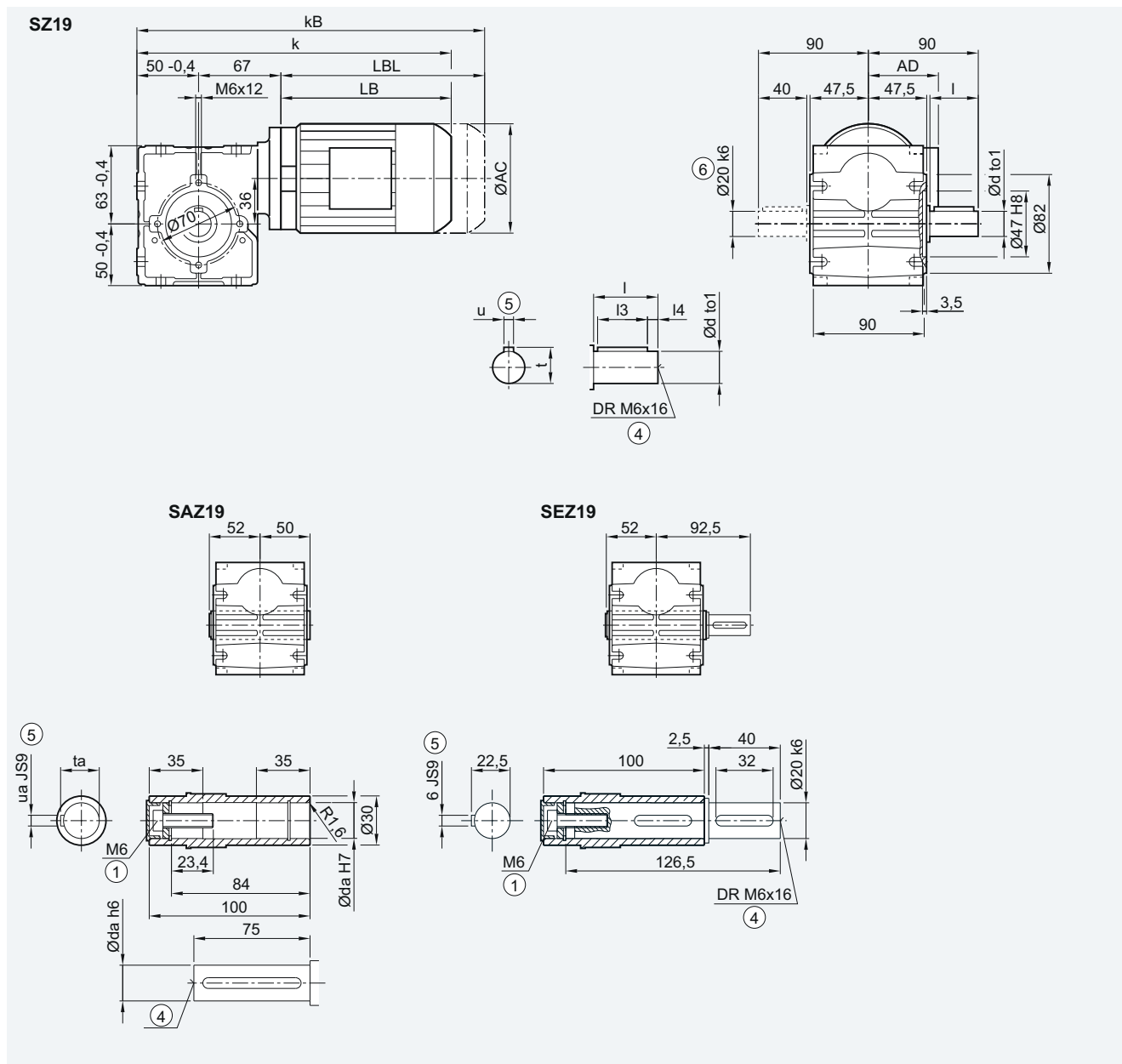

7

Solid shaft	d	to1	l	l3	l4	u	t	Hollow shaft	da	ua	ta
	18	k6	40	31	4	6	20.5		18	6	20.8
	20	k6	40	32	4	6	22.5		20	6	22.8
Motor	AC	AD ¹⁾	k	kB	LB	LBL					
LEI63	117.8	101	296.5	347.5	179.5	230.5					
LEI63Z	117.8	101	322.5	373.5	205.5	256.5					
LEI71	138.8	111	327.0	378.5	210	261.5					
LEI71Z	138.8	111	343.5	398.5	226.5	281.5					
LEI71Y	138.8	111	383.5	438.5	266.5	321.5					

① ISO 4014

② DIN 332

③ Feather key/keyway DIN 6885-1

④ Solid shaft with 2nd shaft extension only d20

¹⁾ AD depends on the motor options, for other dimensions, see page 9/53.

Worm geared motors

1-stage

Gearbox SAD19 in a shaft-mounted design

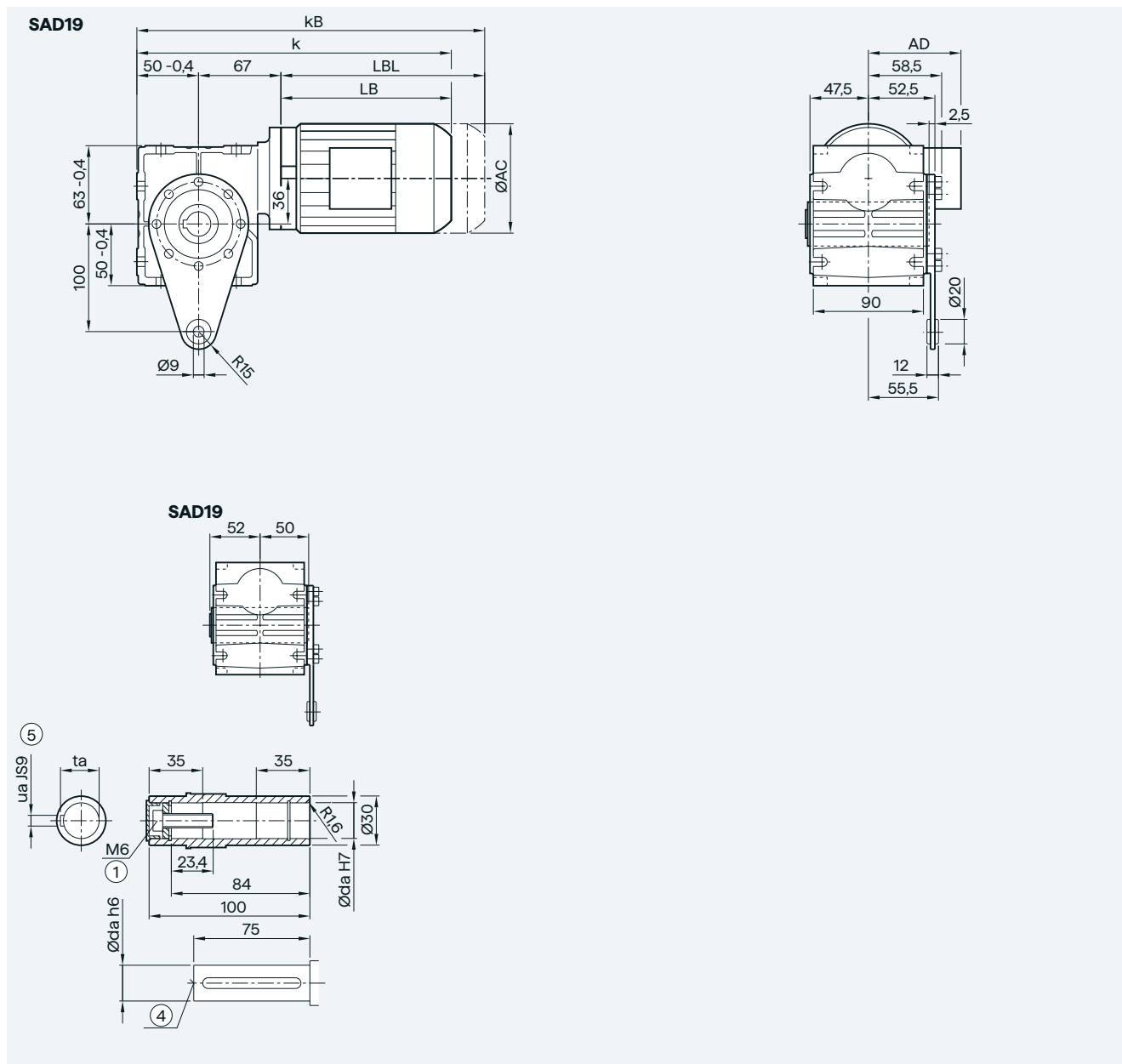

7

Hollow shaft	da	ua	ta			
	18	6	20.8			
	20	6	22.8			
Motor	AC	AD ¹⁾	k	kB	LB	LBL
LEI63	117.8	101	296.5	347.5	179.5	230.5
LEI63Z	117.8	101	322.5	373.5	205.5	256.5
LEI71	138.8	111	327.0	378.5	210.0	261.5
LEI71Z	138.8	111	343.5	398.5	226.5	281.5
LEI71Y	138.8	111	383.5	438.5	266.5	321.5

① ISO 4014

② DIN 332

③ Feather key/keyway DIN 6885-1

¹⁾ AD depends on the motor options, for other dimensions, see page 9/53.

Gearbox S.29 in a foot-mounted design

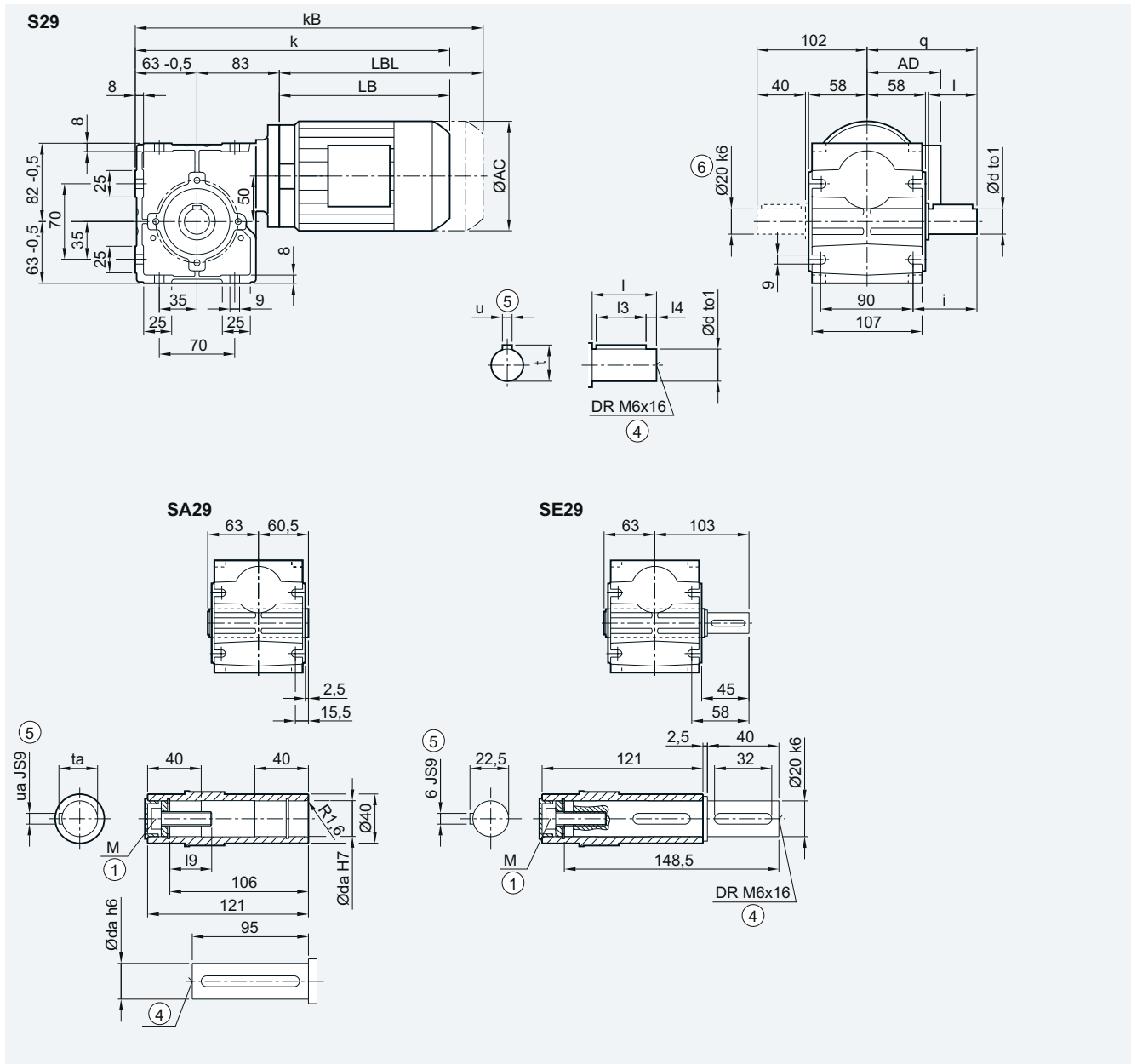

7

Solid shaft	d	to1	l	l3	l4	u	t	q	i	Hollow shaft	da	ua	ta	l9	M
		20	k6	40	32	4	6	22.5	102		57		20	6	22.8
	25	k6	50	40	5	8	28.0	112	67		25	8	28.3	32.6	M10
Motor	AC	AD ¹⁾		k		kB		LB		LBL					
LEI63	117.8	101		325.5		376.5		179.5		230.5					
LEI63Z	117.8	101		351.5		402.5		205.5		256.5					
LEI71	138.8	111		356.5		407.5		210.5		261.5					
LEI71Z	138.8	111		372.5		427.5		226.5		281.5					
LEI71Y	138.8	111		412.5		467.5		266.5		321.5					

① ISO 4014

② DIN 332

③ Feather key/keyway DIN 6885-1

④ Solid shaft with 2nd shaft extension only d20

¹⁾ AD depends on the motor options, for other dimensions, see page 9/53.

Worm geared motors

1-stage

Gearbox S.F29 in a flange-mounted design

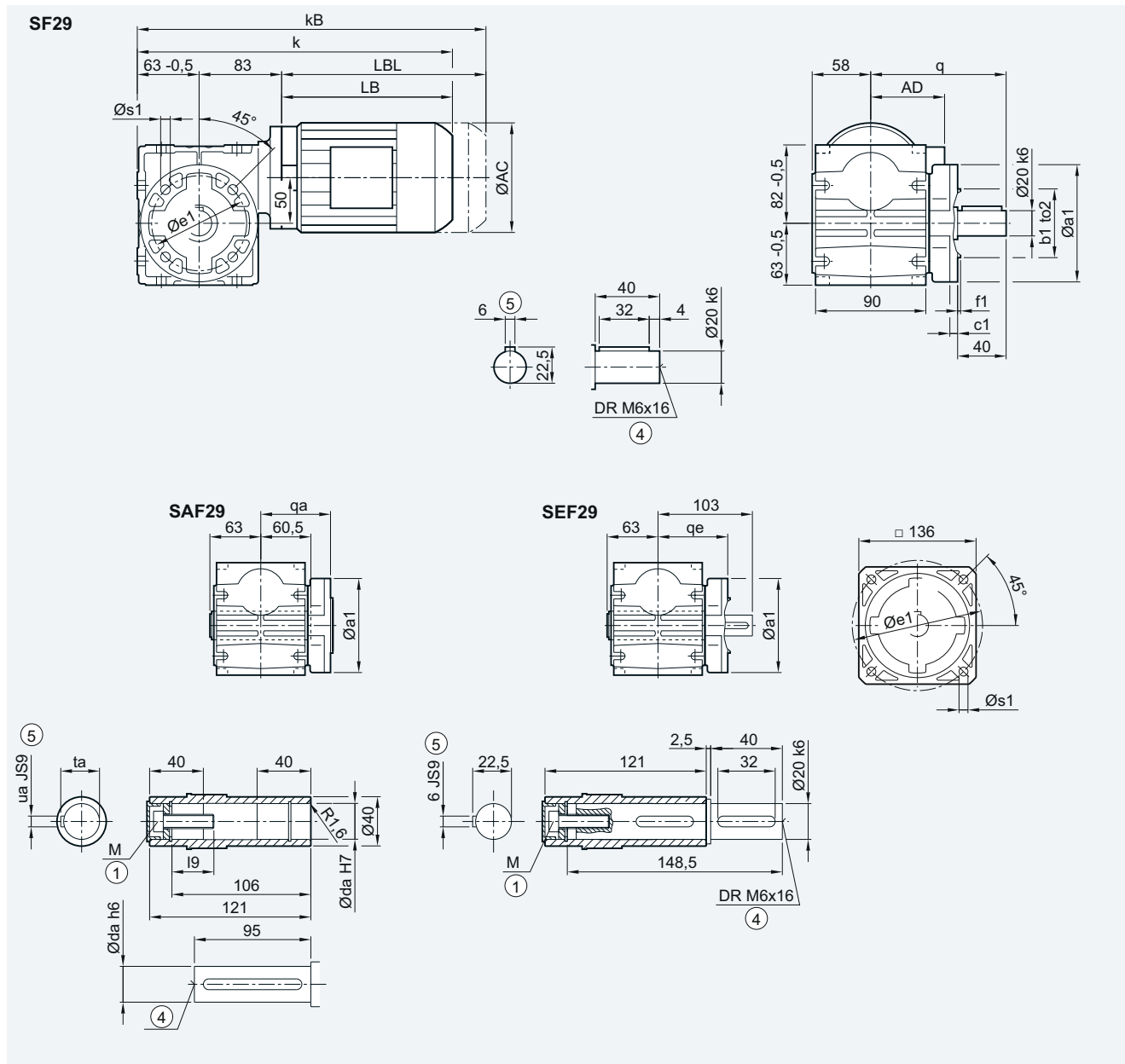

Hollow shaft	da	ua	ta	i9	M				
	20	6	22.8	23.4	M6				
	25	8	28.3	32.6	M10				
Flange	a1	e1	b1	to2	c1	f1	s1	q	qa / qe
	120	100	80	j6	8	3.0	6.6	120	80
	160	130	110	j6	8	3.5	9.0	135	85
Motor	AC	AD ¹⁾	k	kB	LB	LBL			
LEI63	117.8	101	325.5	376.5	179.5	230.5			
LEI63Z	117.8	101	351.5	402.5	205.5	256.5			
LEI71	138.8	111	356.5	407.5	210.5	261.5			
LEI71Z	138.8	111	372.5	427.5	226.5	281.5			
LEI71Y	138.8	111	412.5	467.5	266.5	321.5			

① ISO 4014

② DIN 332

③ Feather key/keyway DIN 6885-1

¹⁾ AD depends on the motor options, for other dimensions, see page 9/53.

Gearbox S.Z29 in a housing flange design

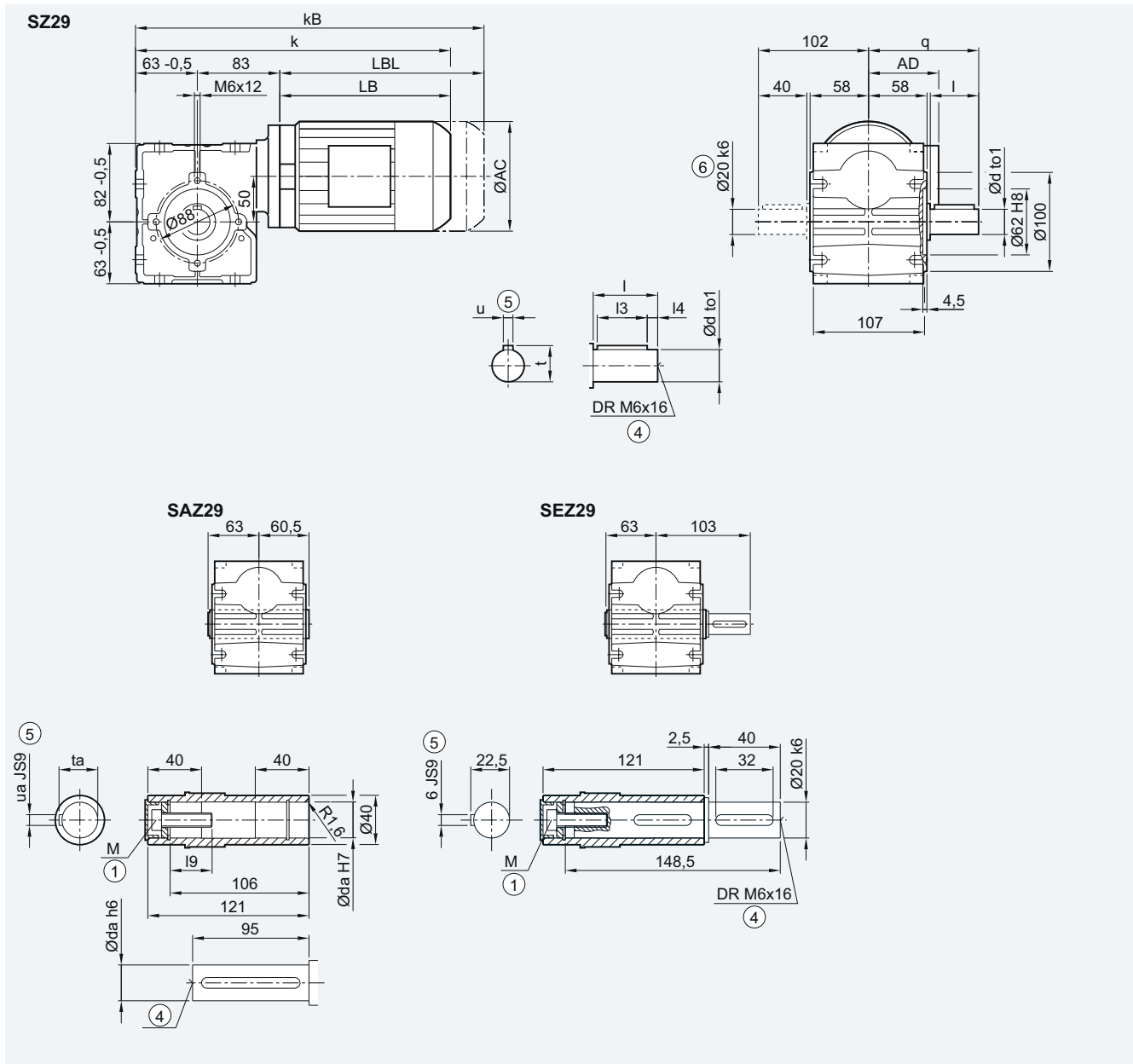

7

Solid shaft	d	to1	l	l3	l4	u	t	q	Hollow shaft	da	ua	ta	l9	M
		20	k6	40	32	4	6	22.5		102		20	6	22.8
	25	k6	50	40	5	8	28.0	112		25	8	28.3	32.6	M10
Motor	AC	AD ¹⁾		k		kB		LB	LBL					
LEI63	117.8	101		325.5		376.5		179.5	230.5					
LEI63Z	117.8	101		351.5		402.5		205.5	256.5					
LEI71	138.8	111		356.5		407.5		210.5	261.5					
LEI71Z	138.8	111		372.5		427.5		226.5	281.5					
LEI71Y	138.8	111		412.5		467.5		266.5	321.5					

① ISO 4014

② DIN 332

③ Feather key/keyway DIN 6885-1

④ Solid shaft with 2nd shaft extension only d20

¹⁾ AD depends on the motor options, for other dimensions, see page 9/53.

Worm geared motors

1-stage

Gearbox SAD29 in a shaft-mounted design

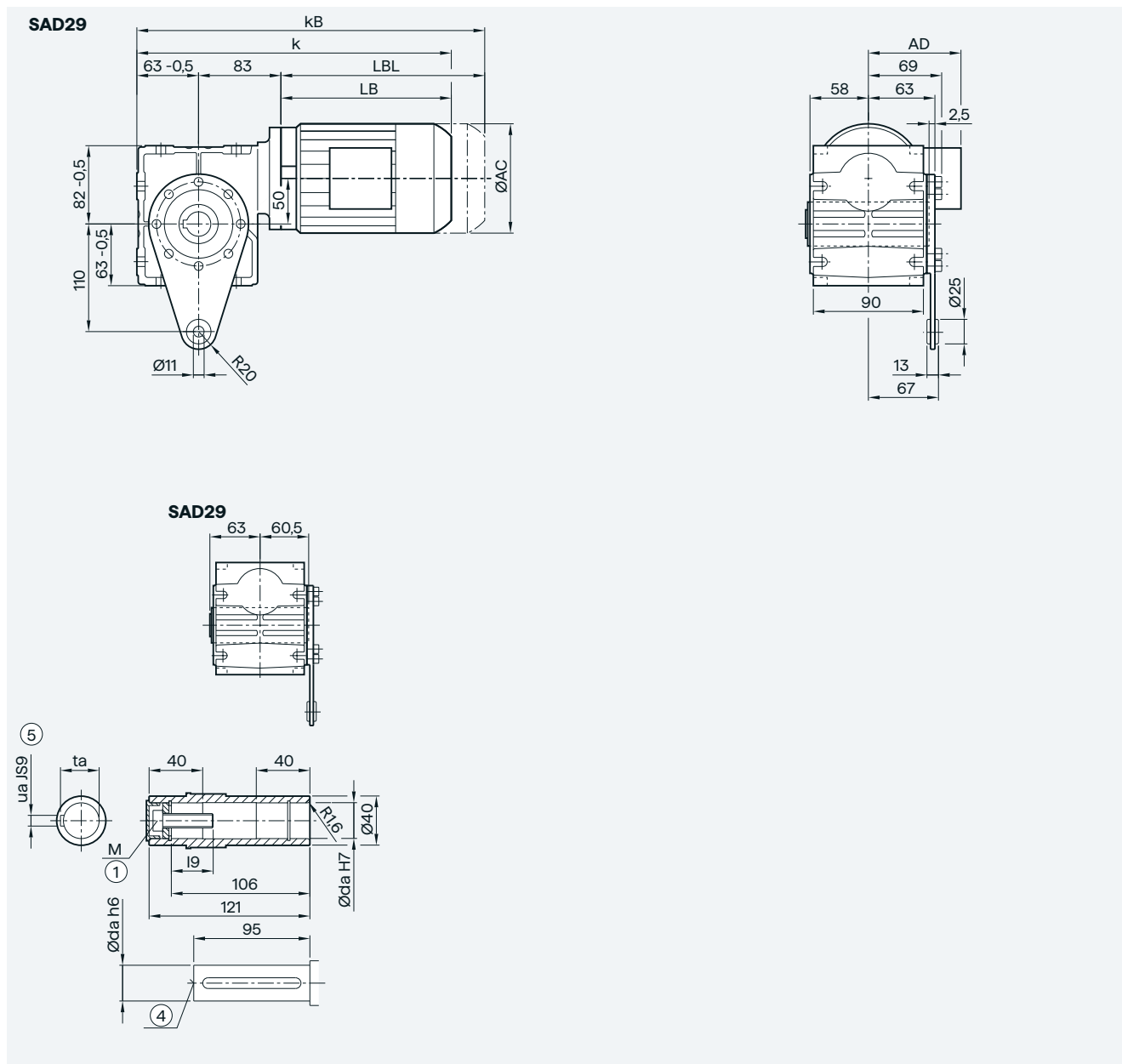

7

Hollow shaft	da	ua	ta	I9	M
	20	6	22.8	23.4	M6
	25	8	28.3	32.6	M10

Motor	AC	AD ¹⁾	k	kB	LB	LBL
LEI63	117.8	101	325.5	376.5	179.5	230.5
LEI63Z	117.8	101	351.5	402.5	205.5	256.5
LEI71	138.8	111	356.5	407.5	210.5	261.5
LEI71Z	138.8	111	372.5	427.5	226.5	281.5
LEI71Y	138.8	111	412.5	467.5	266.5	321.5

① ISO 4014

② DIN 332

③ Feather key/keyway DIN 6885-1

¹⁾ AD depends on the motor options, for other dimensions, see page 9/53.

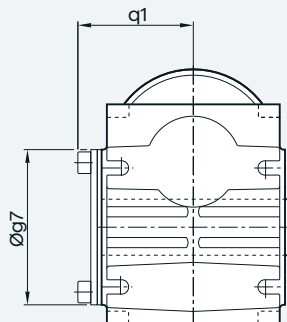
Protective cover for hollow shaft**SA, SAZ, SAF, SE, SEZ**

Gearbox type	S.09	S.19	S.29
Protective cover			
$g7$	72	82	100
$q1$	51	59.5	70